



# UTILITY CART

## DESCRIPTION

The material of the **UTILITY CART** is HDPE made through an injection molding process that gathers higher resistance to impacts and avoids deformations.

- It includes three shelves for organizing different types of materials.
- High-quality aluminum posts for greater resistance.
- Easy to move thanks to its four swivel casters.
- Handles on both sides for better maneuver.
- It has the option of adding a *Silverware Bin*.
- UV protection.
- It's highly resistant to weather conditions.



## FUNCTIONALITY

The **UTILITY CART** helps move more materials efficiently and safely throughout a facility.

## CUSTOMIZATION

According to your needs, it can be labeled with your logo or the type of material it contains.

## FEATURES

4" swivel casters.

**COLOR:** Light gray.

**WEIGHT:** 38.50 lb.

### GENERAL MEASURES:

**Length:** 3 ft 4 in.

**Width:** 19.57 in.

**Height:** 3 ft 1 in.

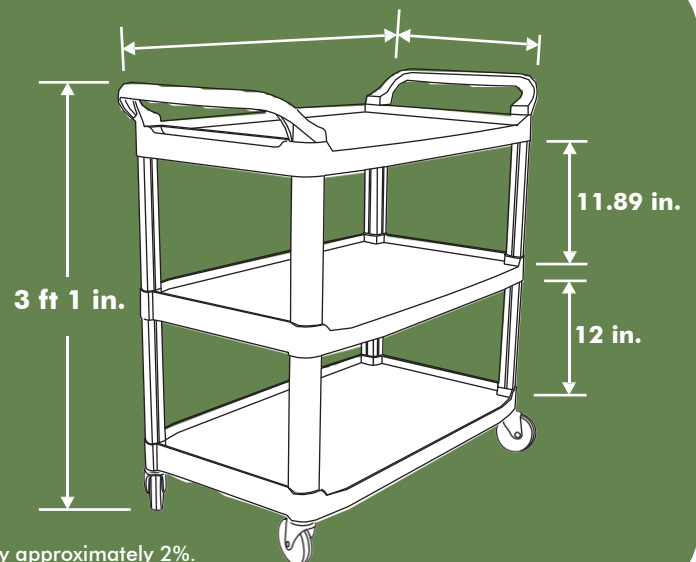

Volumes, dimensions, and other measures are nominal and may vary by approximately 2%.



**PERFECT FOR THE HOTEL INDUSTRY.**



Lago Ajarza # 88-A, Bodega H-Bis, Col. San Diego Ocoyoacac, Del. Miguel Hidalgo C.P. 11290, Mexico City.

Phones: (+52) 55 5527 2498 and 55 5386 4683

info@a1contenedores.com.mx

www.a1contenedores.com.mx